

# RAD-Galaxy 2

## 12-Port 1000BASE-T1 Active Tap and Gateway for Automotive Ethernet with CAN FD

### Your Go-To Tool for Software Defined Vehicles and Zonal Networks Testing

Intrepid's RAD-Galaxy 2 is a multi-purpose Ethernet Active Tap and Gateway for Automotive Ethernet. It has 12x 100/1000BASE-T1 PHYs, allowing it to tap 6 links between ECUs and/or switch ports for monitoring traffic between devices. The ports can also be used independently to connect up to 12 devices to a PC for simulation, testing and parallel ECU flashing. In addition to its Automotive Ethernet capabilities, it offers 8x CAN FD channels, DoIP/SoAD support and 1x 10GBASE-T port.



### Features

- 12x 100/1000BASE-T1 using the Marvell 88Q2112 PHY
    - 6x Active Taps
    - 6-way H-MTD Connector
  - 1x 10GBASE-T port
  - 8x ISO CAN FD channels with selectable on-board termination
  - 1 DoIP activation line
  - 4 GB internal RAM for full speed capture and buffering
  - Flexible media conversion between any of the RAD-Galaxy 2's 100/1000BASE-T1 and 100/1000/10GBASE-T PHYs
  - Fully supports Wireshark and Vehicle Spy
  - Time synchronization with autonomous logging systems using gPTP
  - Isolated ix Industrial™ IP20 connection for PC connection, depending on configuration
  - 10-40V power range, compatible with in-vehicle power
  - LEDs to show link, error, and activity status
  - Automatic power management wake up modes
- \* - BroadR-Reach® devices also supported

### Applications

- ECU level and system level automated testing
- Automotive Ethernet Tap
- Parallel reflashing of up to 12x ECUs
- Automotive Ethernet to CAN FD
- SoAd/DoIP/ISO 15765 reflashing over Automotive Ethernet or CAN FD



H-MTD Connectors for High-speed 1000BASE-T1 networks

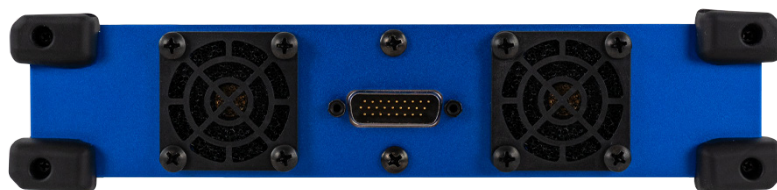

DB26 HD Vehicle signal connector compatible with various Intrepid cables



**INTREPID**  
CONTROL SYSTEMS  
www.intrepidcs.com

1850 Research Drive  
Troy, MI 48083 USA  
Phone: +1 (586) 731-7950  
Fax: +1 (586) 731-2274



automotive  
engineering  
tool alliance  
www.aeta-rice.com

# RAD-Galaxy 2

## Active Tap Configuration

One use of the RAD-Galaxy 2 is to act as an active tap with 6x 1000BASE-T1 taps, transparently tapping between devices. These can be any combination of six ECU-to-switch or ECU-to-ECU links. The traffic from each device on a tapped link is forwarded to its partner, ensuring seamless operation of the network. Copies of all messages/streams are also aggregated and sent to the PC over the RAD-Galaxy's 10G Ethernet link, where they can be analyzed using Vehicle Spy software.

## Independent Ports Mode

The Rad-Galaxy 2 can be used to connect up to 12x 100/1000BASE-T devices to a computer. This is helpful for a number of use cases such as simulation, testing, diagnostics, and Parallel ECU flashing. In addition, any of the Ethernet ports can be bridged internally allowing media conversion between BASE-T and BASE-T1 devices.

## Central Gateway Testing

The RAD-Galaxy 2 is uniquely configured to test central gateways. Connect to the "clean" and "dirty" side of the central gateway with four Ethernet ports, as well as the 8x CAN FD networks. All data is synchronized with better than 10 ns accuracy.

## Automotive Ethernet PHY Testing

RAD-Galaxy 2's user-friendly and powerful design allows you to validate and debug physical layer/PHY issues. The RAD-Galaxy 2 provides PHY-level information including signal quality measurement, master/slave or negotiation modes, and other status available from the PHY.

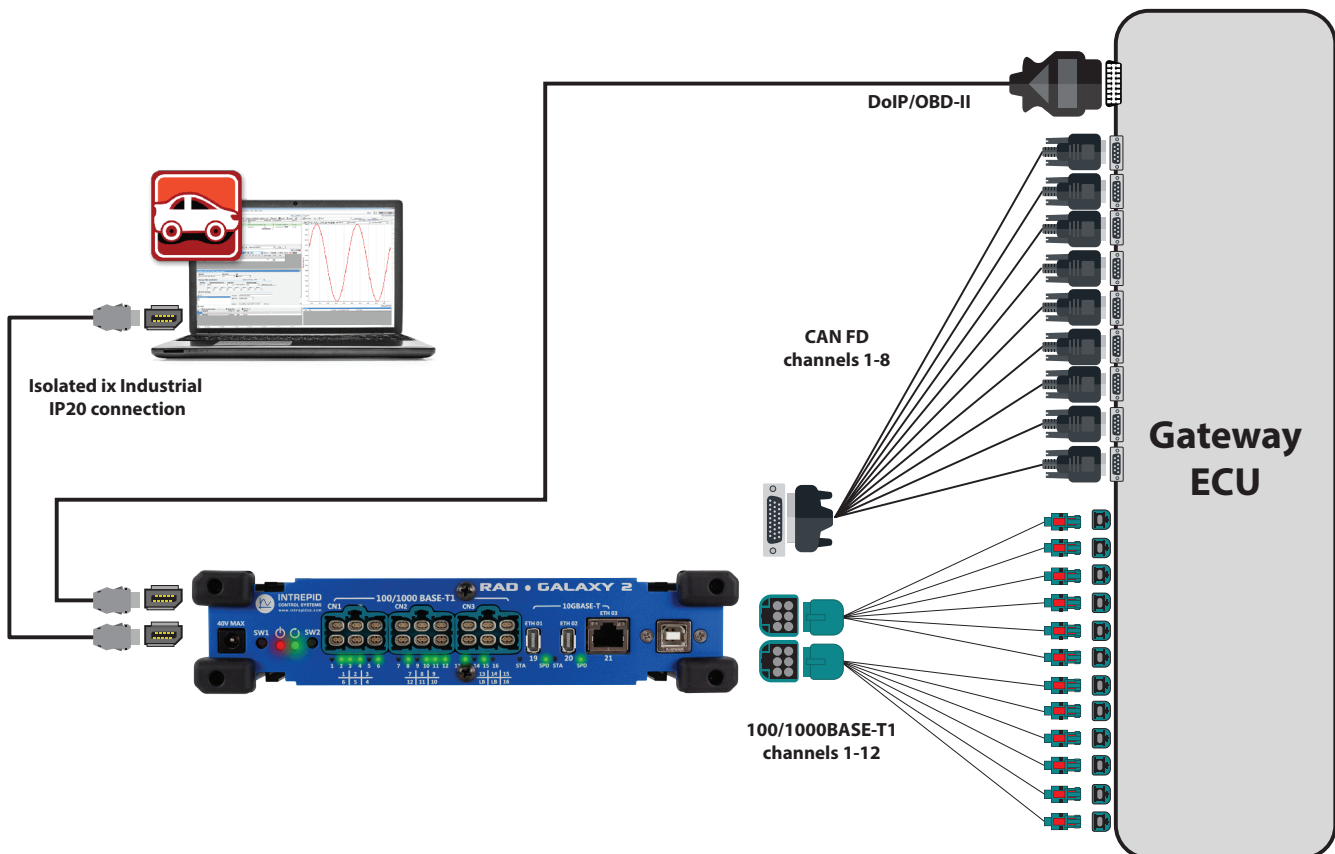

**INTREPID**  
CONTROL SYSTEMS  
www.intrepidcs.com

1850 Research Drive  
Troy, MI 48083 USA  
Phone: +1 (586) 731-7950  
Fax: +1 (586) 731-2274



www.aeta-rice.com

# RAD-Galaxy 2

## Device Specifications

- Low power consumption
- Power Supply: 10-40V operation
- 16 LEDs indicate link status
- LEDs (user programmable):
  - 19 programmable tri-color LEDs
- Temperature Range: -40°C to +85°C
- One-year limited warranty
- Field-upgradeable flash firmware
- DAQ Ethernet
- J2534 and RP1210 A/B compatible for CAN / ISO 15765- 2:2016 (CAN FD)
- Battery-backed real time clock (RTC).
- Dimensions: 211 mm x 44.3 mm x 171.3 mm
- Weight: 1000g

## Timing Specifications

- FPGA-measured 64-bit timestamping with 10 ns accuracy on all CAN/LIN/Ethernet networks
- Simultaneous operation on all CAN/LIN/Ethernet networks
- Transmit message double-buffering on all networks, allowing back-to-back message transmission

## Network Specifications – Automotive Ethernet

- 12x 100/1000BASE-T1 Marvell 88Q2112 PHYAutomotive Ethernet physical layer transceivers
- PHYs can be configured to operate as active taps for up to 6 node pairs, media converters for up to 12 nodes, or a combination of up to 6
- Full-duplex operation on all links
- Automatic master/slave configuration

## Timing Specifications

- 64-bit timestamping to an accuracy of 25 nanoseconds on all networks
- Simultaneous operation on all CAN networks
- Transmit message double-buffering on all networks, allowing back-to-back message transmission

## Network Specifications – CAN

- 8 x ISO CAN FD channels
- CAN 2.0B compatible for all CAN networks
- 8 dedicated ISO11898 Dual Wire CAN FD physical layers (TJA1043)
- Listen-only mode support

## Network Specifications – DoIP/XCP/Automotive Ethernet

- 110/100/1000 Ethernet PHY with low-power mode
- DoIP activation line implemented with LIN channel

## Ordering Information

Part Number	Description
RAD-Galaxy 2	12-Port 1000BASE-T1 Active Tap and Gateway for Automotive Ethernet with CAN FD

Specifications subject to change; please contact Intrepid for the latest information. All trademarks are the property of their respective owners.

Rev. 20240403



**INTREPID**  
CONTROL SYSTEMS  
www.intrepidcs.com

1850 Research Drive  
Troy, MI 48083 USA  
Phone: +1 (586) 731-7950  
Fax: +1 (586) 731-2274



www.aeta-rice.com